

PARTS LIST

MCA-PT2407(10)

CONTENTS

1. MCA-PT2407(10).....	1 ~ 4
------------------------	-------

2015. 12.



P/N 524068

EXPLODED VIEW OF UNIVERSAL POLE PRUNER ATTACHMENT COD. 2309

SPARE PART/KIT NUMBER	CODE	DESCRIPTION	QUANTITY
1	2331	GEAR KIT POLE PRUNER	1
2	2332	ADJUSTMENT KIT POLE PRUNER	1
3	2333	KIT BAR AND CHAIN	1
4	2334	OIL PUMP KIT	1
5	1308	OIL TANK COMPLETE	1
6	2323	HEXAGONAL FLANGED NUT M8X1.25 UNI 6923	1
7	2298	CHAIN COVER	1
8	2288	PINION 1-4	1
9	2272	GEARBOX BODY	1
10	2300	CHAIN TENSIONER ASSY	1
11	2295	OIL CAP ASSEMBLY	1
.12	8472620	SET TUBETTI OLIO	

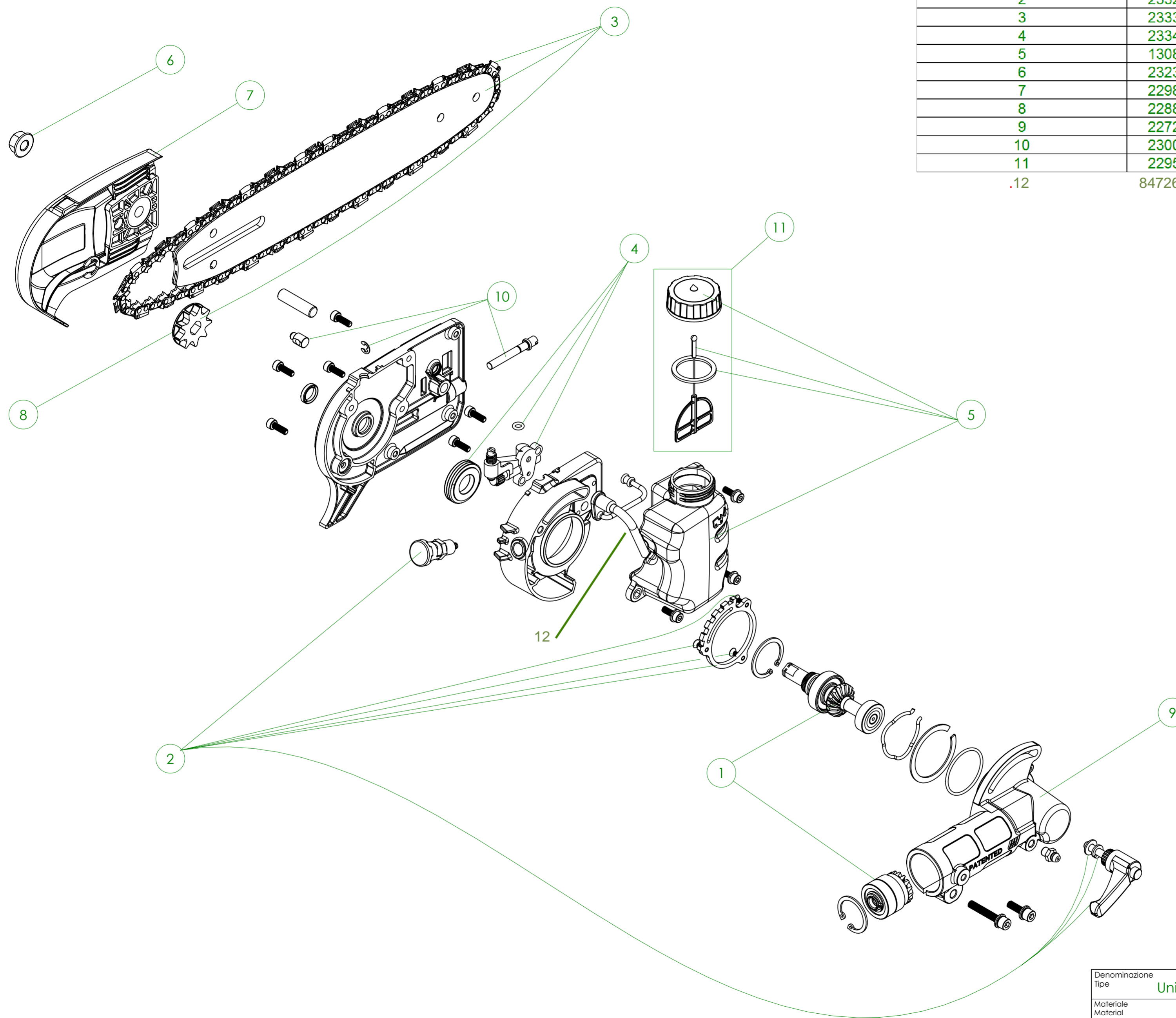

Rugosità superf.
Surf. roughness

Denominazione Type Universal pole pruner attachment		Scale 1:2	
Materiale Material	Tratt. superf. Surface treatment	Macchina Project Universal pruner	Drawn M.G.
Colore Colour	Ricavato da: Obtained from:	Peso Weight g	Checked A.G.
Trattamento termico Heat treatment		Resist. N/mm ²	Date 04/07/2018
Profondità Cmt. Depth Cmt.		upward s.r.l. Engineering Tel. +39 059 527327	
Durezza Hardness		Note	

02	Added Oil cap assembly code	M. G. A. G.	04-09-2019
01	Added spare parts	M. G. A. G.	11-01-2019
Esp.	Modifica - Revision	Disegn. Drawn	Visto Contr. Date

VIETATO RIPRODURRE O DIVULGARE IL PRESENTE DISEGNO SENZA NOSTRA AUTORIZZAZIONE SCRITTA
 IT IS STRICTLY FORBIDDEN TO DIVULG THIS TECHNICAL DRAWING WITHOUT THE PERMISSION OF UPWARD
 QUOTE SENZA INDICAZIONE DI TOLLERANZA GRADO DI PRECISIONE MEDIO EN 22768-1 CON PRECISIONE DI COLLAUDO
 MEASURE WITHOUT TOLERANCES PRECISION GRADE MEDIUM REF. EN 22768-1